

Acylindrical Equation

$$Z(y) = \frac{c^2 y^2}{1 + \sqrt{1 - (k + 1)c^2 y^2}} + \sum_{i=2}^8 A_{2i} y^{2i}$$

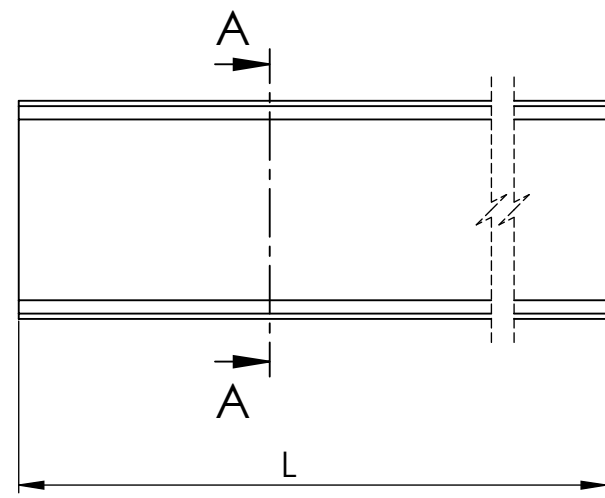
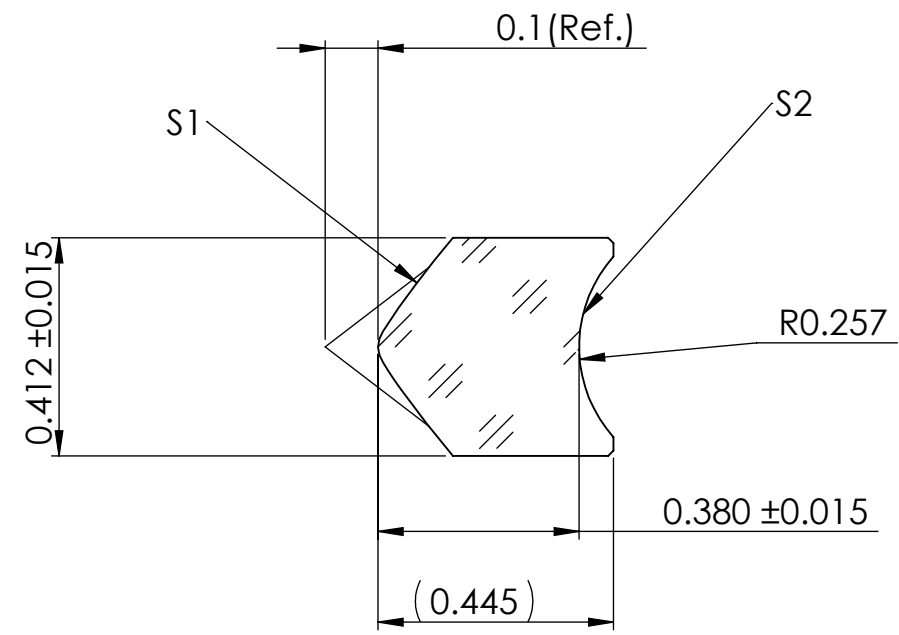

Acylindrical Coefficients

	S1	S2
R	0.0860	0.257
c	11.6279	
k	-3.1416	
A ₂	0.0000	
A ₄	0.0000	
A ₆	0.0000	
A ₈	0.0000	
A ₁₀	0.0000	
A ₁₂	0.0000	
A ₁₄	0.0000	

Sagittal Distances of Acylindrical Surface

Y (mm)	Z(mm)	
	S1	S2
0.0	0.000000	0.000000
0.103	0.04090	0.02148
0.2061	0.10634	0.10305

SECTION A-A
SCALE 70 : 1

All unspecified surfaces-fine ground

S1		Material/Lens Data		S2	
Radius of Curvature	0.086 mm	Glass Type	S-TIH53	Radius of Curvature	0.257 mm
Clear Aperture	0.3 mm	n _d / V _d	1.84666 / 23.8	Clear Aperture	0.3 mm
Irregularity	λ/2 over CA	Focal length	-0.07822 mm ± 1%	Irregularity	λ/2 over CA
Centering	Not specified	Numerical Aperture	0.5	Centering	Not specified
Surface Quality	20-10	Design wavelength	532 nm	Surface Quality	20-10
Coating	None			Coating	None

Dimensions in mm
For Information Purposes Only

PROPRIETARY
THE INFORMATION CONTAINED IN THIS DRAWING
IS THE SOLE PROPERTY OF Doric Lenses Inc..
ANY REPRODUCTION IN PART OR AS A WHOLE
WITHOUT THE WRITTEN PERMISSION OF
Doric Lenses Inc. IS PROHIBITED.

DO NOT SCALE DRAWING

doric	doriclenses.com
TITLE: D142-0404 -ACL_CCX_STIH53_VPS-3X-LENS_L	
DWG. NO. D142-0404	
19-8-2019	