

doric

## **Laser Safety Information**

Application Note

Version 3.0.0

---

# Contents

<b>1</b>	<b>Important Safety Information</b>	<b>3</b>
1.1	Abbreviations . . . . .	3
1.2	General laser safety rules . . . . .	3
1.3	Ocular and skin safety . . . . .	3
1.4	Fire and material safety . . . . .	4
1.5	Electrical safety . . . . .	4
<b>2</b>	<b>Light Source Driver Safety Features</b>	<b>5</b>
2.1	Activation Safety Features . . . . .	5
2.2	Emission Indicator . . . . .	6
<b>3</b>	<b>Class 3B Laser Products</b>	<b>7</b>
3.1	Ocular safety limits for point sources . . . . .	7
3.2	General safety considerations for class 3B laser products . . . . .	7
3.3	References . . . . .	8
<b>4</b>	<b>Support</b>	<b>9</b>
4.1	Contact us . . . . .	9

# Important Safety Information

## 1.1 Abbreviations

AEL	Accessible Emission Limit
ANSI	American National Standards Institute
FDA	Food and Drug Administration
IEC	International Electrotechnical Commission
LIA	Laser Institute of America
LSO	Laser Safety Officer
MPE	Maximum Permissible Exposure
NOHD	Nominal Ocular Hazard Distance

## 1.2 General laser safety rules

Using laser light sources requires specific safety procedures. Even at low output power, laser radiation can permanently damage the eyes, induce skin burns and ignite flammable materials. Electrical hazards are also present if the driving electronics are not used properly.

- **BEFORE FIRST USE , establish proper laser safety procedures for an accident, and obtain contact information for local health and safety officers.**
- Secure the laser driver by linking it to an interlock circuit.
- Any area where the laser is not enclosed should be clearly identified to prevent accidental access.
- People in the laser area should be trained in safe laser use or be accompanied by personnel trained in laser use.

## 1.3 Ocular and skin safety

- **ALWAYS WEAR LASER SAFETY GLASSES (goggles) CERTIFIED FOR THE LASER WAVELENGTH AN POWER LEVEL.**
- **NEVER LOOK DIRECTLY INTO A LASER BEAM**, even when wearing laser safety glasses.
- **NEVER BLOCK A LASER BEAM WITH YOUR HANDS OR ANY OTHER BODY PART.**
- Wear tight clothing made of non flammable materials.
- Attach long hair and any other loose accessories (neckties, etc.) that may accidentally be ignited by the laser beam.
- Remove rings, watch, jewelery and any reflective clothing that may accidentally reflect the laser beam outside the setup.
- Laser safety glasses do not eliminate hazards since the laser beam can not be seen through them.
- Always use indirect viewing methods such as laser viewing cards, power detectors, etc.

- A laser beam should always be confined in the setup by using proper beam blocks or beam dumps.
- Do not add/remove/adjust optical components while the laser beam is not attenuated to a safe level.

#### 1.4 Fire and material safety

- Exposure to a laser beam may result in ignition of flammable materials, either solid, liquid or gaseous even at low power, should the beam be tightly focused.
- Most light detectors (photodiodes, CCD cameras, power meter heads, etc.) can be damaged by laser beams. **Ensure that a proper laser beam attenuator is used before exposing any detector to the laser beam.**
- Computer and laboratory instrument screens can reflect laser beams and be damaged by them.

#### 1.5 Electrical safety

- Laser driving electronics may lead to electrical hazards when not used properly. Do not open the housing of laser driving electronics.

## Light Source Driver Safety Features

### 2.1 Activation Safety Features

The drivers for all Doric Lenses light sources come with a number of safety features. These are built into the driver circuits, as shown in the block diagram (Fig. 2.1).

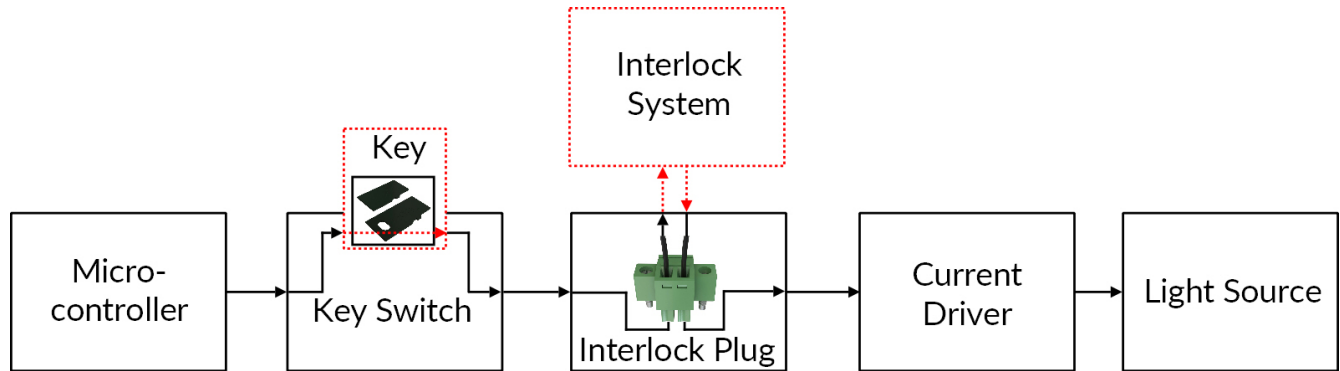
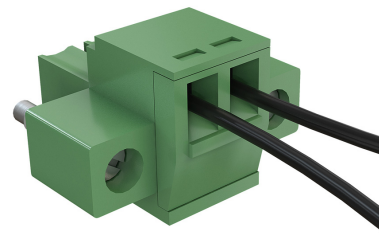

Figure 2.1: Safety feature block diagram

- The **Micro-controller**, **Key Switch**, **Interlock Plug** and **Current Driver** are connected in series. This means that if any single safety feature is not properly in place, the light source cannot be activated.
- The **Micro-controller** is used to control the light source driver.



(a) Key Switch



(b) Interlock Plug

Figure 2.2: Safety Feature Elements

- The **Key Switch** (Safety feature 1) (Fig. 2.2a), located on the left side of the driver, is required to activate any light source. If removed, no data can be sent from the micro-controller to the **Current Driver**.
- The **Interlock plug** (Safety feature 2) (Fig. 2.2b) is used to integrate the driver into an **Interlock Circuit**.

- The **Interlock Plug** comes with a small wire short-circuiting it. This wire must be removed before integrating it into an **Interlock Circuit**.
- Connect the **Interlock circuit** in series with the **Interlock Plug** so the circuit may function properly.
- The **Current Driver** sends current to any connected light source. If the **Key** is absent or the **Interlock Plug** has an open circuit, it cannot receive signals from the micro-controller, preventing it from sending out current.

## 2.2 Emission Indicator

For light sources emitting invisible laser radiation, a dedicated LED indicator is ON when the driver is outputting an electrical current. When the driver is outputting current, the light source will emit light from the aperture.

## Class 3B Laser Products

### 3.1 Ocular safety limits for point sources

According to ANSI Z136.1-2014<sup>[1]</sup>, class 3B laser products:

- Have a maximum **Accessible Emission Limit** (AEL) equal to 500 mW for wavelengths ( $\lambda$ ) between 400 nm and 700 nm.
- Have exposure durations (t) between 0.25 s and  $3 \times 10^4$  s.
- The ocular **Maximum Permissible Exposure** (MPE) for point sources in the 450 nm to 700 nm range is 1 mW/cm<sup>2</sup>.
- Direct viewing of the optical beam from any distance below the **Nominal Ocular Hazard Distance**(NOHD) is hazardous for the eyes.
  - Considering the angular divergence at the output of Doric *Connectorized Laser Diode Modules* and Doric *Laser Diode Fiber Light Sources* the **NOHD is typically larger than one meter (model dependant)** for the free-space optical beam exiting from the output FC connector.
- Damages can occur faster than the “blink reflex” of the eyes.
- Wearing certified laser safety glasses (goggles) is **highly recommended** when the output laser beam is not properly attenuated or confined within the optical setup.

### 3.2 General safety considerations for class 3B laser products

According to IEC60825-1<sup>[2]</sup>, class 3B laser products are defined as follows:

*Laser products that are normally hazardous when intra-beam ocular exposure occurs (i.e. within the NOHD: Nominal Ocular Hazard Distance) including accidental short time exposure. Viewing diffuse reflections is normally safe. Class 3B lasers which approach the AEL for Class 3B may produce minor skin injuries or even pose a risk of igniting flammable materials. However, this is only likely if the beam has a small diameter or is focused.*

*NOTE: There exist some theoretical (but rare) viewing conditions where viewing a diffuse reflection could exceed the MPE. For example for Class 3B lasers having powers approaching the AEL, lengthy viewing of greater than 10 s of true diffuse reflections of visible radiation and viewing at distances less than 13 cm between the diffusing surface and the cornea can exceed the MPE.*

According to ANSI Z136.1-2014<sup>[1]</sup>, class IIIB laser products:

*May be hazardous under direct and specular reflection viewing conditions, but is normally not a reflection hazard, diffuse reflection hazard, nor a laser generated air contaminant (LGAC) production hazard.*

According to ANSI Z136.1-2014<sup>[1]</sup> and the FDA<sup>[3]</sup>, the requirements for class IIIB laser products are:

- Engineering Controls (see section 2)

- Training
- Designation of a *laser safety officer* (LSO)

### 3.3 References

1. American National Standards Institute (ANSI), ANSI Z136.1-20014, American National Standard for Safe Use of Lasers  
<https://www.lia.org/store/product/106>
2. International Electrotechnical Commission (IEC), IEC60825-1:2014-05, Edition 3.0 Safety of laser products – Part 1: Equipment classification and requirements,  
[http://webstore.iec.ch/webstore/webstore.nsf/Artnum\\_PK/49687](http://webstore.iec.ch/webstore/webstore.nsf/Artnum_PK/49687)
3. U.S. Food and Drug Administration (FDA), 2014 21CFR1040.10 Code of Federal Regulations, Title 21, Volume 8, Revised as of April 1, 2014 PART 1040, Sec. 1040.10 Laser products.  
<http://www.accessdata.fda.gov/scripts/cdrh/cfdocs/cfCFR/CFRSearch.cfm?FR=1040.10>



---

## Support

### 4.1 Contact us

For any questions or comments, do not hesitate to contact us by:

**Phone** 1-418-877-5600

**Email** [sales@doriclenses.com](mailto:sales@doriclenses.com)

The logo for Doric Lenses, featuring the word "doric" in a lowercase, sans-serif font. The letter 'o' is stylized with a white highlight on its left side, giving it a three-dimensional appearance.

© 2021 DORIC LENSES INC

357 rue Franquet - Quebec, (Quebec)

G1P 4N7, Canada

Phone: 1-418-877-5600 - Fax: 1-418-877-1008

[www.doriclenses.com](http://www.doriclenses.com)