



Imaging Cannula Implantation & Microscope Installation for eTFMB/eTOSFM

Application Note

Version 1.0.0

Contents

1	Selection of the Imaging Cannula Parameters	3
1.1	Twist-on efocus Imaging Cannula Model L (eTICL) overview	3
1.2	Cannula type	4
1.3	Field of view	5
1.4	Protrusion Adjustment Ring	5
2	Implantation of the Imaging Cannula	7
2.1	Twist-on Cannula Removal and Installation	7
2.2	Fluorescence Microscope Holder Installation	10
2.3	Animal Surgical Preparation	11
2.4	Protrusion adjustment ring installation	12
2.5	Type-L Cannula Implantation	12
2.6	Securing the Cannula on the Skull	14
2.7	Tissue Healing and Training of the Animal (3 weeks or more)	15
3	Imaging Sessions	16
3.1	Head-fixed configuration	16
3.2	Freely-moving configuration	16
4	Handling & Cleaning	18
4.1	Important handling information	18
4.2	Cleaning optics	18
4.3	Imaging cannula reuse	18
5	Support	19
5.1	Contact us	19

Selection of the Imaging Cannula Parameters

1.1 Twist-on efocus Imaging Cannula Model L (eTICL) overview

The depth of the region-of-interest determines the choice of microscope body and imaging cannula. For brain regions up to 8.1 mm in depth, the *Model-L Cannula* is implanted within the brain, with the *Model-L Microscope* allowing imaging of brain tissue at these locations (Fig. 1.1). Three parameters need to be taken into account when selecting an imaging cannula for an experiment: the GRIN lens penetration depth (section 1.2), the cannula field of view (section 1.3), and the protrusion adjustment ring height (section 1.4).



Figure 1.1: *Miniature Fluorescence Microscopes In Exploded Format*

1.2 Cannula type

Depending on the depth of the region-of-interest inside the subject's brain, three types of *Twist-on efocus Imaging Cannula* are available (LD, LV or LE) with different lens protrusion lengths. While the type LV and LE cannulas have a GRIN rod lens diameter of 0.5 mm, the type LD cannula can have a GRIN rod diameter of 0.5 mm or 1.0 mm. Table 1.1 gives the range of penetration depth obtained for the 0.5 mm diameter GRIN rod lens cannulas, and Table 1.2 for the 1.0 mm diameter GRIN rod lens cannula. The penetration depth is measured from the surface of the skull, or the bottom of the protrusion adjustment ring, to the region-of-interest.

Table 1.1: Range of Penetration Depth For 0.5 mm Rod Lens Cannulas

Cannula type	Range of penetration depth d (mm) ¹
LD	0 - 3.3
LV	2.7 - 5.7
LE	5.1 - 8.1

Table 1.2: Range of Penetration Depth For 1.0 mm Rod Lens Cannula

Cannula type	Range of penetration depth d (mm) ¹
LD	0 - 2.6

The working distance of the *Twist-on efocus Imaging Cannula Model L* represents the distance from the extremity of the relay lens to the object focal plane. The working distance has an adjustment range of 350 μm : from -30 μm (inside the GRIN rod lens) to 320 μm , with a depth of field of 50 μm (Fig. 1.2). The working distance must be considered when calculating the required penetration depth.

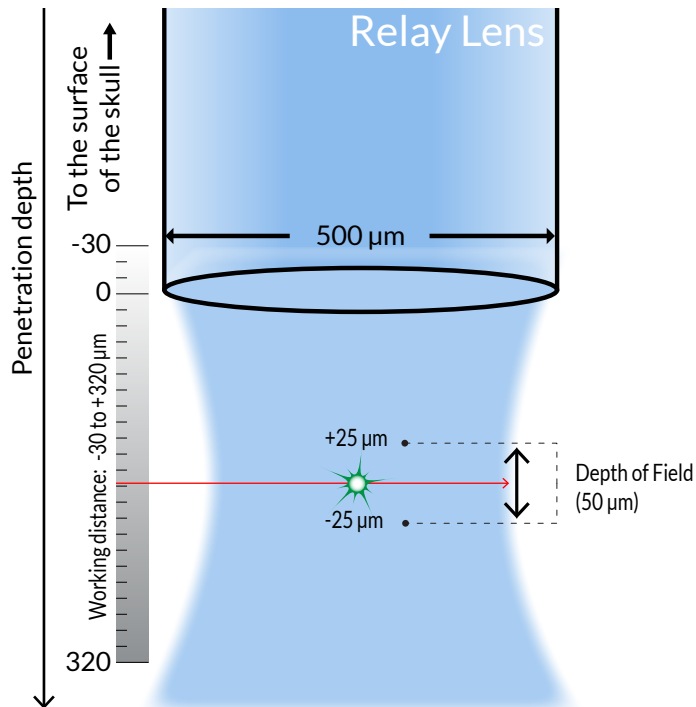
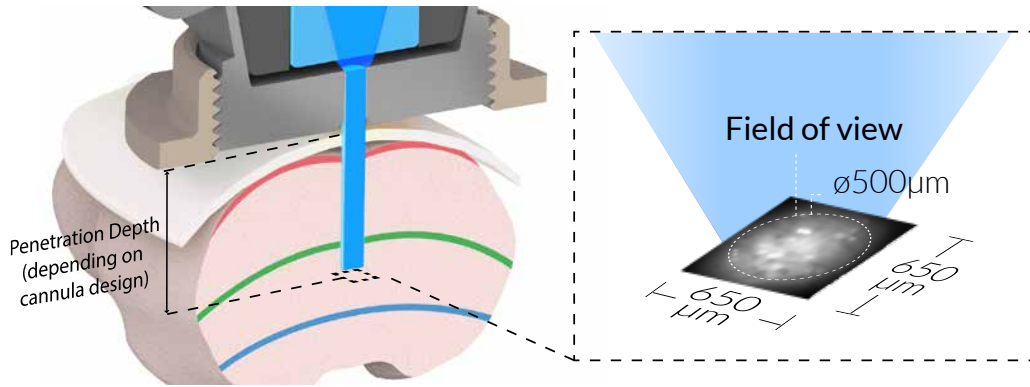

Figure 1.2: *Twist-on efocus Imaging Cannula* working distance and depth of field.

¹Including the skull thickness and a working distance of 80 μm .

1.3 Field of view

The *Twist-on efocus Imaging Cannula Model L* has two available GRIN rod lens diameters: 0.5 mm and 1.0 mm. The field of view depends on the diameter of the GRIN rod lens. The field of view of the eTFMB/eTOSFM microscope when using a 0.5 mm diameter GRIN rod lens cannula is a 500 μm diameter circular area (Fig. 1.3a). The field of view of the eTFMB/eTOSFM microscope when using a 1.0 mm diameter GRIN rod lens cannula is 650 μm X 650 μm square area (Fig. 1.3b). Although the field of view is larger, when using a 1.0 mm diameter GRIN rod lens, the footprint of the rod lens inside the brain is also higher.



(a) With a 0.5 mm Diameter GRIN Rod Lens.

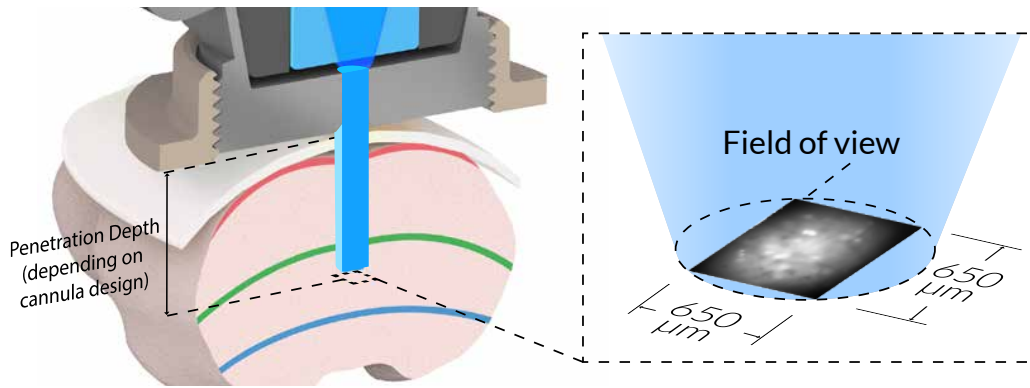

(b) With a 1.0 mm Diameter GRIN Rod Lens.

Figure 1.3: *Twist-on efocus Imaging Cannula Field of View Characteristics.*

1.4 Protrusion Adjustment Ring

To ensure that the *Twist-on efocus Imaging Cannula Model L* is well secured on the skull, it is recommended to combine the imaging cannula with a *Protrusion Adjustment Ring*. To select the right protrusion ring, follow these steps.

1. Measure the protrusion length (L) (Fig. 1.4) of the lens from the bottom of the metal part of the cannula to the extremity of the lens.
2. Determine at which penetration depth you want to position the extremity of the lens in the subject's brain. Add to this measure the thickness of the skull and the working distance of the GRIN rod lens (80 μm). To ensure that the Protrusion Adjustment Ring will not be too low, it is recommended to add 100 μm to this measure. You will obtain the protrusion distance (d) (Fig. 1.4) representing the distance from the tip of the lens to the bottom of the Protrusion Adjustment Ring. ($d = \text{penetration depth} + \text{skull thickness} + \text{working distance}(80 \mu\text{m}) + 100 \mu\text{m}$).
3. The protrusion of the ring (p) (Fig. 1.4) is given by : $p = L - d$ and can be related to the Protrusion Adjustment Ring with closest matching protrusion length (Table 1.3). Each ring is identified by its height (h) (Fig. 1.4).

- Place the selected Protrusion Adjustment Ring on the cannula and adjust the position of the ring to obtain the required protrusion distance (d).

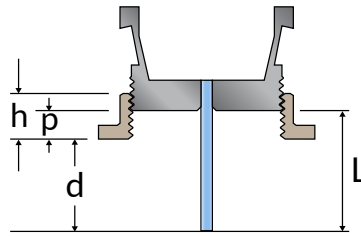

Figure 1.4: Protrusion Adjustment Ring Parameters.

Table 1.3: Protrusion Adjustment Ring Model L Selection

Ring #	Height (h) (mm)	Protrusion Length (p) (mm)
1	2.0	0 - 1.5
2	2.7	0.7 - 2.2
3	3.4	1.4 - 3.0
4	4.2	2.2 - 3.7
5	4.9	2.9 - 4.4

Implantation of the Imaging Cannula

The following section describes the handling and implantation of the *eTFMB/eTOSFM* microscope bodies and related cannulas.

Note: Images of the *2-color Fluorescence Microscope Bodies (2CFM-L)* are used as an example in the surgical implantation figures as the process is identical for all microscope types.

2.1 Twist-on Cannula Removal and Installation

The *Twist-on efocus Microscope Body* is removed and installed in a cannula in a completely different fashion than the Snap-in models. The present section describes how to manipulate the Twist-on connection system. The microscope body is delivered with a protective cannula that should be removed at first use and re-installed after each imaging session to protect the microscope. To remove the protective cannula and install the imaging cannula on the microscope body, follow the procedure described in this section. Handle the microscope and cannula with care. The GRIN rod lens and objective lens are fragile and any stain or scratch can affect image quality. **Do not touch the surface of the lenses.**



(a) Twist-on efocus Microscope body with protective cannula.

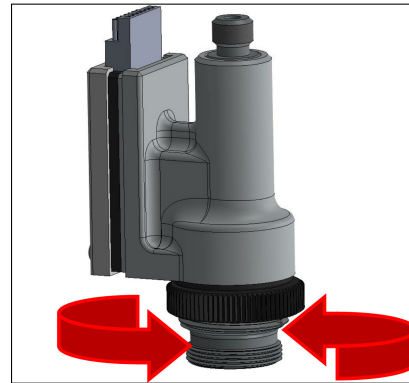

(b) Unscrew the microscope barrel.

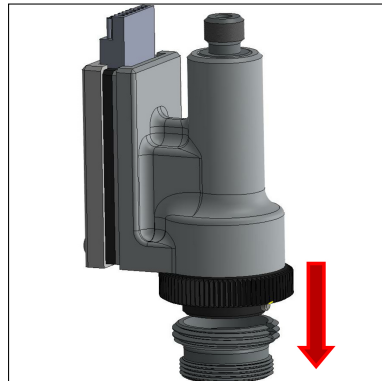

(c) Remove the protective cannula.

Figure 2.1: Cannula Removal Procedure.

1. Remove the **Protective Cannula** from the *Microscope Body* (Fig. 2.1). The *Twist-on efocus Imaging Cannulas* is also removed the same way.
 - a) The microscope is provided with a protective cannula (Fig. 2.1a)
 - b) Unscrew the **Microscope Barrel** from the **Cannula Connection Thread**(Fig. 2.1b).
 - c) Remove the protective cannula (Fig. 2.1c).
2. Install the *Microscope Body* in the **Twist-on efocus Imaging Cannula** (Fig. 2.2). Any other *Twist-on efocus Imaging Cannula* is installed the same way.
 - a) Unscrew the **Cannula Input Protective Cap** to remove it (Fig. 2.2a).
 - b) Place the microscope body on the imaging cannula (Fig. 2.2b).
 - c) Ensure that the **Microscope Key** is properly inserted in the **Cannula Slot** (Fig. 2.2c). If the key is properly slotted, the microscope will be unable to turn inside the cannula .
 - d) Screw the **Microscope Barrel** on the **Cannula Connection Thread** (Fig. 2.2d).
 - e) If the cannula is not already implanted in a subject, remove the **Output Protective Cap** from the cannula by unscrewing it (Fig. 2.2e). Take great care to remove it in a straight motion so as not to touch or break the GRIN rod lens.
 - f) The *Twist-on efocus Microscope* is now ready for implantation or experimental use (Fig. 2.2f).

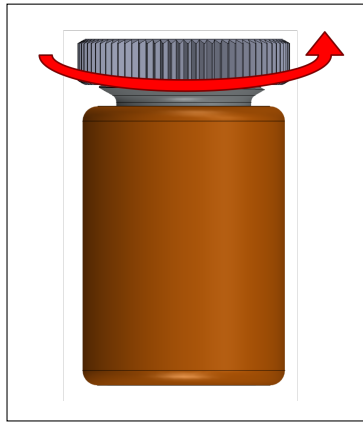

(a) Unscrew the Input Protective Cap.

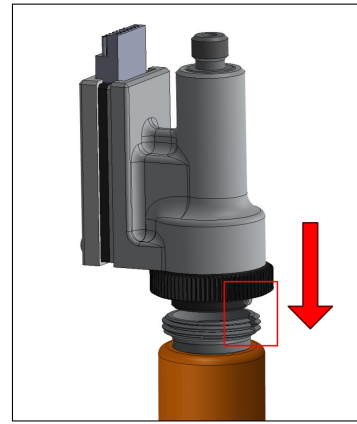

(b) Place the microscope body in the cannula.

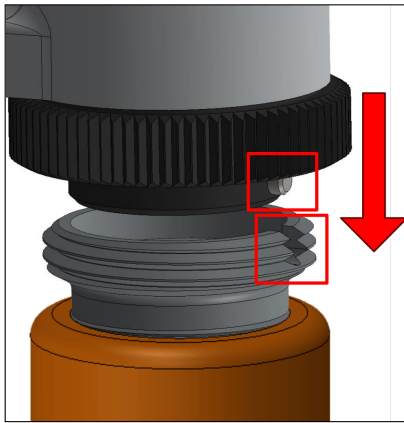

(c) Ensure that the microscope key is properly inserted in the cannula slot.

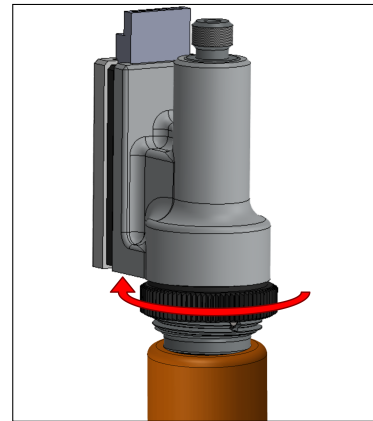

(d) Screw the barrel on the cannula connection thread.

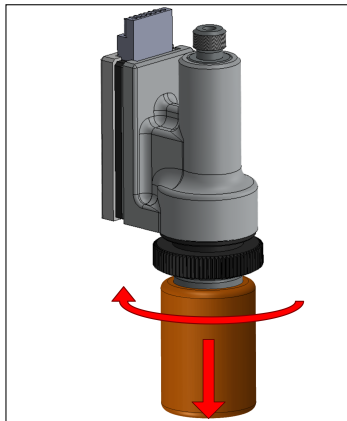

(e) Unscrew the Cannula Output Protective Cap.

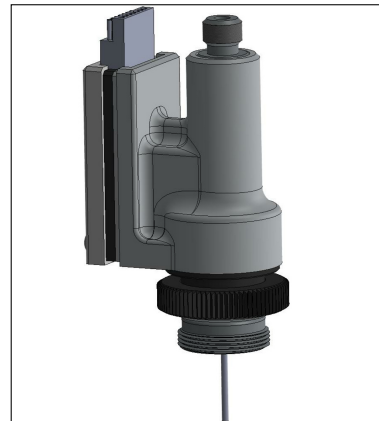

(f) Ready for implantation.

Figure 2.2: Cannula Installation Procedure

2.2 Fluorescence Microscope Holder Installation

For cannula implantation, the microscope can be secured on its *Fluorescence Microscope Holder*. The holder allows imagery during the descent of the relay lens into the brain. Experiments not requiring a freely-moving animal can be done with this head-fixed configuration. The 2CFM-L is used as an example in the following figures as the process is identical for all microscope types.

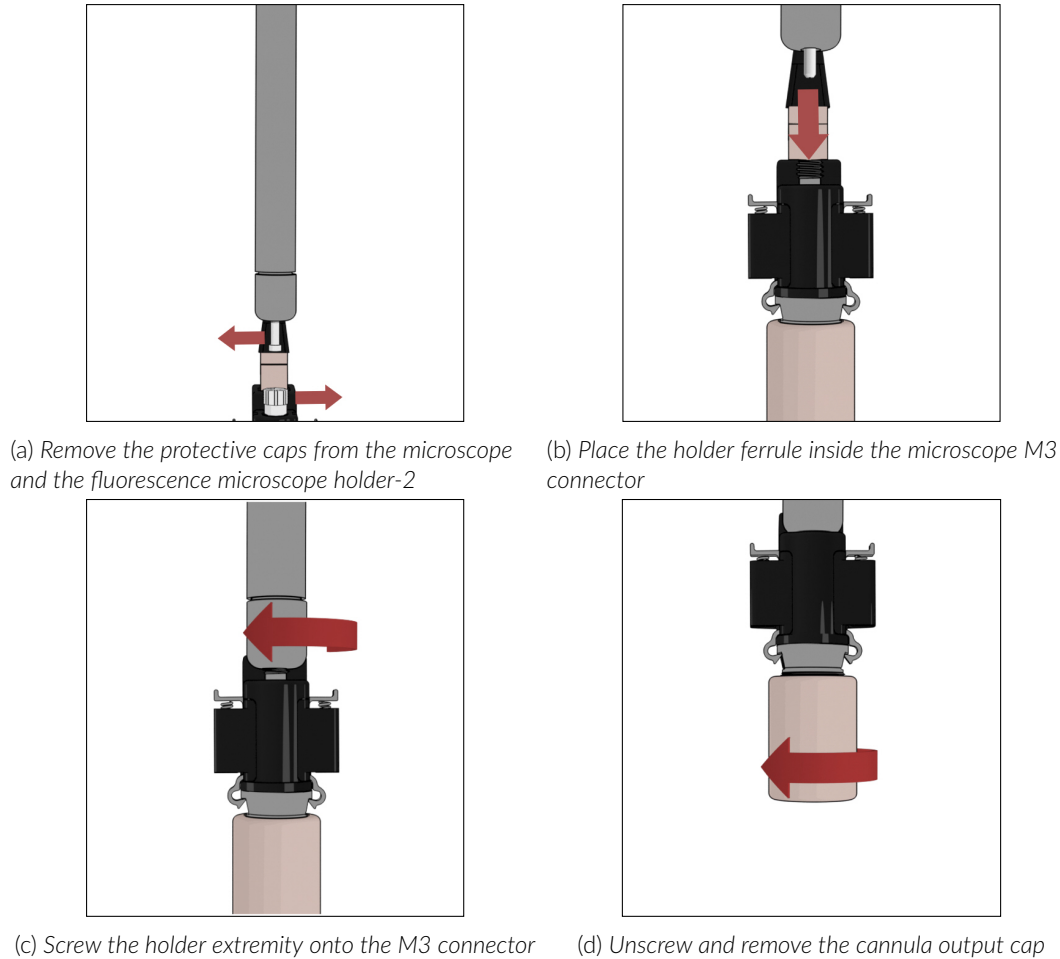

Figure 2.3: Cannula Installation Procedure

1. Install the microscope onto the *Fluorescence Microscope Holder 2 (FMH_2)*.
 - a) Remove the **Connector Caps** from the microscope **M3 Optical Connector** and the **Fluorescence Microscope Holder 2 ferrule** (Fig. 2.3a). Clean the **Fluorescence Microscope Holder 2 ferrule** tip using a lint-free wipe and isopropyl alcohol before the next step.
 - b) Insert the ferrule into the **M3 Optical Connector** (Fig. 2.3b). Secure them in place by screwing the **Fluorescence Microscope Holder 2 barrel** (Fig. 2.3c).
 - c) Install the *Fluorescence Microscope Holder 2* into a stereotaxic apparatus.
 - d) When ready for use, remove the **Output Protective Cap** from the cannula by unscrewing it (Fig. 2.3d). If using a type-L cannula, take great care to remove it in a straight motion so as not to touch or break the rod lens.
2. Before implantation, remove the protective cap and start the acquisition system to check the image quality obtained. Make sure **not to touch the surface of the lens**. If the image shows spots, there may be dust on the lens. Use a cotton swab to clean the tip of the lens with acetone or isopropyl alcohol. **Never dip the lens in acetone**. After this test close the acquisition system.

2.3 Animal Surgical Preparation

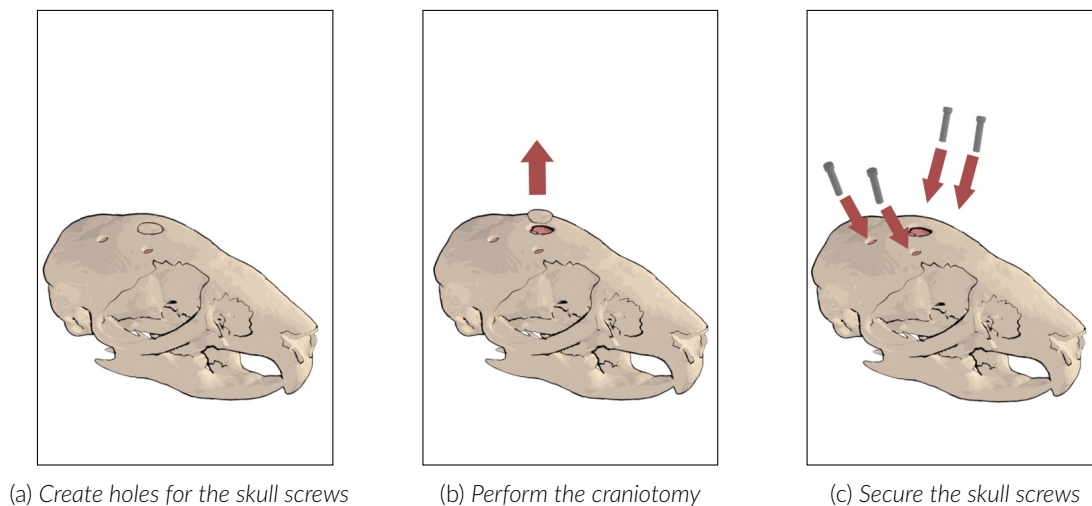

Figure 2.4: *Surgical Preparation*

Before implantation, the animal subject must be prepared. This includes the placement of **Skull Screws** to secure the cannula, and a craniotomy to allow observation of the brain¹.

1. Determine the stereotaxic coordinates for cannula implantation.
2. Drill holes to allow the placement of skull screws (Fig. 2.4a). This requires a distance of at least 5 mm from craniotomy center to allow rotation of the *Protrusion Adjustment Ring*.
3. Perform the craniotomy (Fig. 2.4b). When using a type-L cannula, the hole must have a diameter larger than the rod lens diameter. When using a type-S cannula, the hole must have a diameter of at least 2 mm.
4. Place 4 supporting screws in the prepared holes around the craniotomy site (Fig. 2.4c).

¹Skull screws not provided with microscope

2.4 Protrusion adjustment ring installation



(a) Place glue drops into cannula thread

(b) Thread the protrusion adjustment ring onto the cannula.

Figure 2.5: Protrusion Adjustment Ring Installation

To prepare for implantation, the *Protrusion Adjustment Ring* must first be installed. The *Protrusion Adjustment Ring* is used to stabilize the system on the skull when the implanted cannula is at the appropriate depth. Its position is determined by the depth of the structure of interest relative to the top of the skull (see section 1.4).

1. Place a couple of drops of a slow drying glue (e.g. epoxy adhesive) to secure the ring to the metal thread of the imaging cannula².
 - **Be careful not to apply glue on the microscope body or the imaging lens.**
 - A slow drying will allow small adjustments during implantation.
 - Each full rotation of the protrusion adjustment ring represents a vertical distance of 300 μm .
2. Attach the proper protrusion adjustment ring to the cannula at its approximate position. For type-L cannulas, place the *Protrusion Adjustment Ring* in a slow, vertical motion to avoid making contact with the rod lens.
3. Once the *Protrusion Adjustment Ring* is in place, the microscope can be moved above the animal subject.

2.5 Type-L Cannula Implantation

When using a type-L cannula, the rod lens must penetrate the brain. Only type-L microscope bodies are capable of using a type-L cannula. The following section details the standard method of cannula implantation.

2.5.1 Setting the Depth reference

When using a type-L cannula, a depth reference must be taken on the brain surface with the tip of the relay lens.

1. Place the microscope above the prepared animal subject. Lower the system into the craniotomy hole, so that the tip of the rod lens is touching the brain surface without penetrating it.
 - Given the size of the cannula, the tip can be difficult to see. A mirror or a camera can be helpful to see exactly when the extremity of the lens touches the brain.
2. When the reference point is found, note it and elevate the microscope.
3. Carefully remove the dura from the reference point. A clean brain surface without any bleeding will allow optimal image quality while lowering the rod lens.

²Glue not provided with microscope

2.5.2 Implantation of the Cannula

From the beginning to the end of implantation, handle the imaging cannula with care. The relay lens is very fragile and any stain or scratch can affect image quality.

1. Connect the *Fluorescence Microscope Holder 2* to the illumination system.
2. Slowly lower the rod lens (around 1 $\mu\text{m/s}$) to allow proper tissue penetration (Fig. 2.6a).
 - The *Fluorescence Microscope Holder 2* allows illumination during the implantation of the lens.
 - If the cannula is implanted when a sufficient viral expression has been reached, a diffuse fluorescence signal will confirm the positioning of the lens in the targeted area (the injection site).
 - If the cannula is implanted immediately after viral injection, the fluorescence signal cannot be used to confirm the position of the lens in the targeted site.
3. If the imaging cannula is not in the desired area, it is possible to make another descent to place the lens.
4. If there is a significant gap between the *Protrusion adjustment ring* and the skull:
 - Verify that the *Fluorescence Microscope Holder 2* is secure and that the microscope will not move if touched.
 - Slowly unscrew the protrusion adjustment ring to bring it closer to the skull. Stop unscrewing if the **Rod Lens** starts moving inside the brain (Fig. 2.6b).

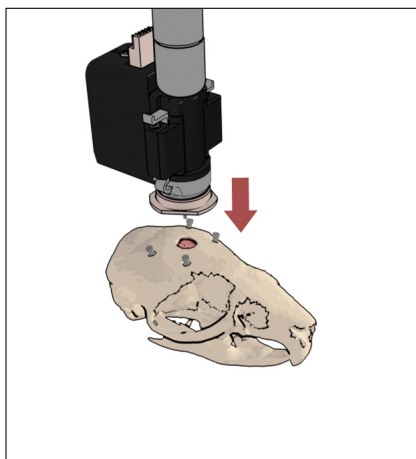

(a) Position the microscope on the skull, lower the lens slowly

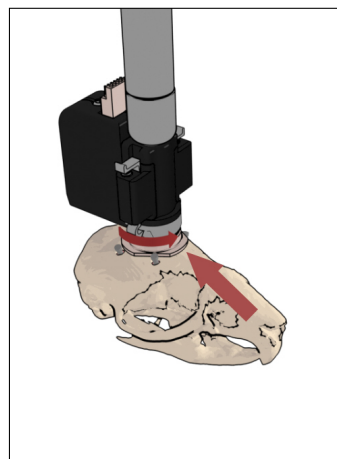

(b) Unscrew the protrusion adjustment ring closer to skull

Figure 2.6: Implantation Preparation

2.6 Securing the Cannula on the Skull

Once the cannula is implanted in the region-of-interest, it is necessary to secure it and the **Protrusion Adjustment Ring** onto the skull.

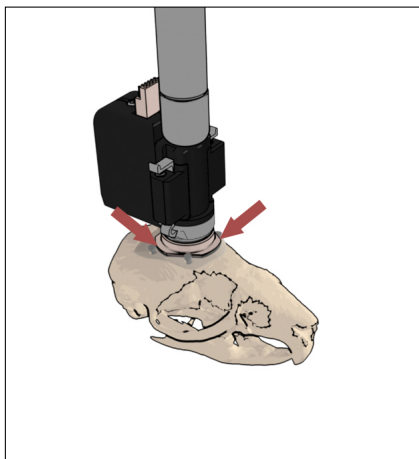

(a) Use a fast drying glue to secure the protrusion adjustment ring on the skull

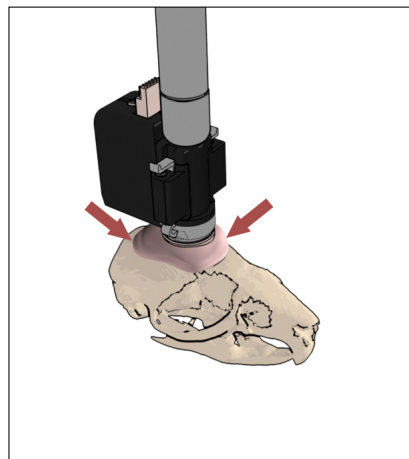

(b) Use dental cement to secure the protrusion adjustment ring on the skull

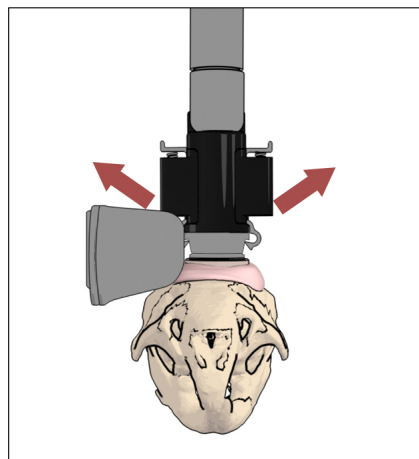

(c) Disconnect the microscope connection system

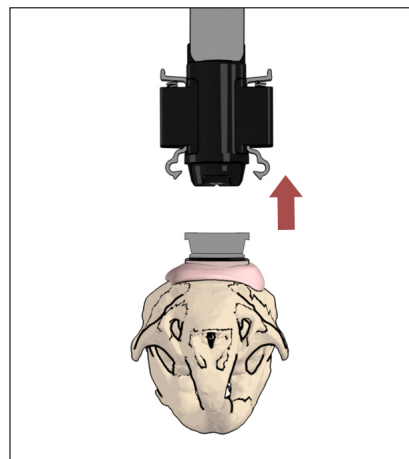

(d) Remove the microscope body from the cannula

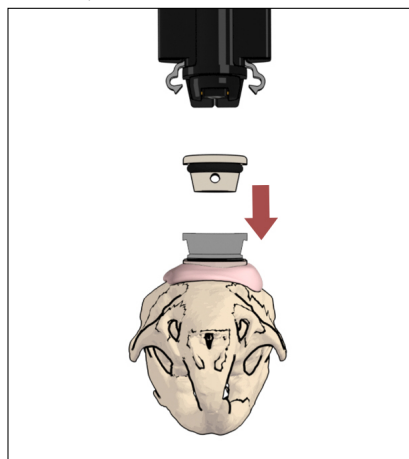

(e) Place the input protective cap on the cannula

Figure 2.7: Securing the Imaging Cannula on the Skull

1. Put a fast drying glue between the **Protrusion Adjustment Ring** and the skull (Fig. 2.7a)³. If the ring is near the bones, the capillary action of a strong adherence liquid glue will ensure that the glue will pass below the ring. Otherwise, a gel glue should be used to fill the gap.
2. To improve support for the screws, it is recommended to put glue on them.
3. When the glue on the surface of the skull is completely dried, secure the microscope to the skull by applying dental cement on the **Protrusion Adjustment Ring** and on the screws (Fig. 2.7b)⁴.
 - If the **Protrusion Adjustment Ring** is not touching the skull, it is important to put some cement on the glue between the ring and the bones to stabilize the system.
 - The **Connection System** must remain free of cement to be able to separate the microscope and the cannula.
 - Tissue, muscles, skin or fur should not come in contact with the dental cement. This is necessary to ensure proper adhesion of the cannula to the skull.
4. Once the dental cement has completely dried, the microscope can be removed. Detach the **Connection System** (Fig. 2.7c).
5. Remove the microscope from the cannula (Fig. 2.7d).
6. Place the **Input Protective Cap** onto the imaging cannula to protect the lens (Fig. 2.7e).
7. Place the protective cannula onto the microscope.
 - If the imaging sessions are done in a head-fixed configuration, the microscope body can be left attached to the *Fluorescence Microscope Holder* until the first imaging session.
 - For freely-moving experiments, unscrew the *Fluorescence Microscope Holder* and put its protective M3 cap to protect the microscope body's optical pathway.

2.7 Tissue Healing and Training of the Animal (3 weeks or more)

Usually, the system can distinguish cells 2 or 3 weeks after the implantation of the cannula. Nonetheless, better image quality is obtained 2-8 weeks after the implantation. The waiting time for tissue repair can be a good period to use the **Twist-on efocus Dummy Microscope** (Fig 2.8). It is important to train the animal, using the dummy, to tolerate the encumbrance of a microscope on its head and to get used to moving easily in its cage with it.



Figure 2.8: *Twist-on efocus Dummy Microscope.*

³Glue not provided with microscope

⁴Dental cement not provided with microscope

Imaging Sessions

The following section describes the basics of an imaging session using the *Twist-on efocus Fluorescence Microscope*.

3.1 Head-fixed configuration

1. Prepare the microscope for a head-fixed configuration session, as described in section 2.2.
2. Before installing the microscope, place the anesthetized subject in a stereotaxic head restraint.
3. Remove the *Input Protective Cap* from the cannula (Fig. 2.2a).
4. Install the microscope in the cannula as shown in figure 2.2. Make sure that the microscope key is properly inserted in the cannula slot before screwing the Microscope Barrel. The stereotaxic head restraint decreases the pressure applied on the head of the animal when the microscope body is secured in the implanted cannula.
5. Complete the connections of the system as described in the [Twist-on efocus Fluorescence Microscope System User Manual](#).
6. Open the *Doric Neuroscience Studio* software and the imaging session of the region-of-interest can start. For more information about the use of the Doric Neuroscience Studio Software, please refer to the [Doric Neuroscience Studio User Manual](#).

3.2 Freely-moving configuration

1. Prepare the microscope for a freely-moving configuration session as shown in Fig. 3.1 (for more informations, please refer to the [Twist-on efocus Fluorescence Microscope System User Manual](#)).
2. Remove the *Input Protective Cap* from the cannula (Fig. 2.2a).
3. Install the microscope in the cannula as shown in figure 2.2. Make sure that the microscope key is properly inserted in the cannula slot before screwing the Microscope Barrel. The anaesthetized animal can be placed in a stereotaxic head restraint to decrease the pressure applied on its head when the microscope body is secured in the implanted cannula.
4. Let the animal recover from the anaesthesia and remove the animal from the stereotaxic apparatus (if applicable).
5. Open the *Doric Neuroscience Studio* software and the imaging session of the region-of-interest can start. For more information about the use of the Doric Neuroscience Studio Software, please refer to the [Doric Neuroscience Studio User Manual](#).
 - During behavior imaging sessions, it is recommended to put the metal shield at the base of the ultralight cable to protect it from animal interference, such as chewing or scratching.

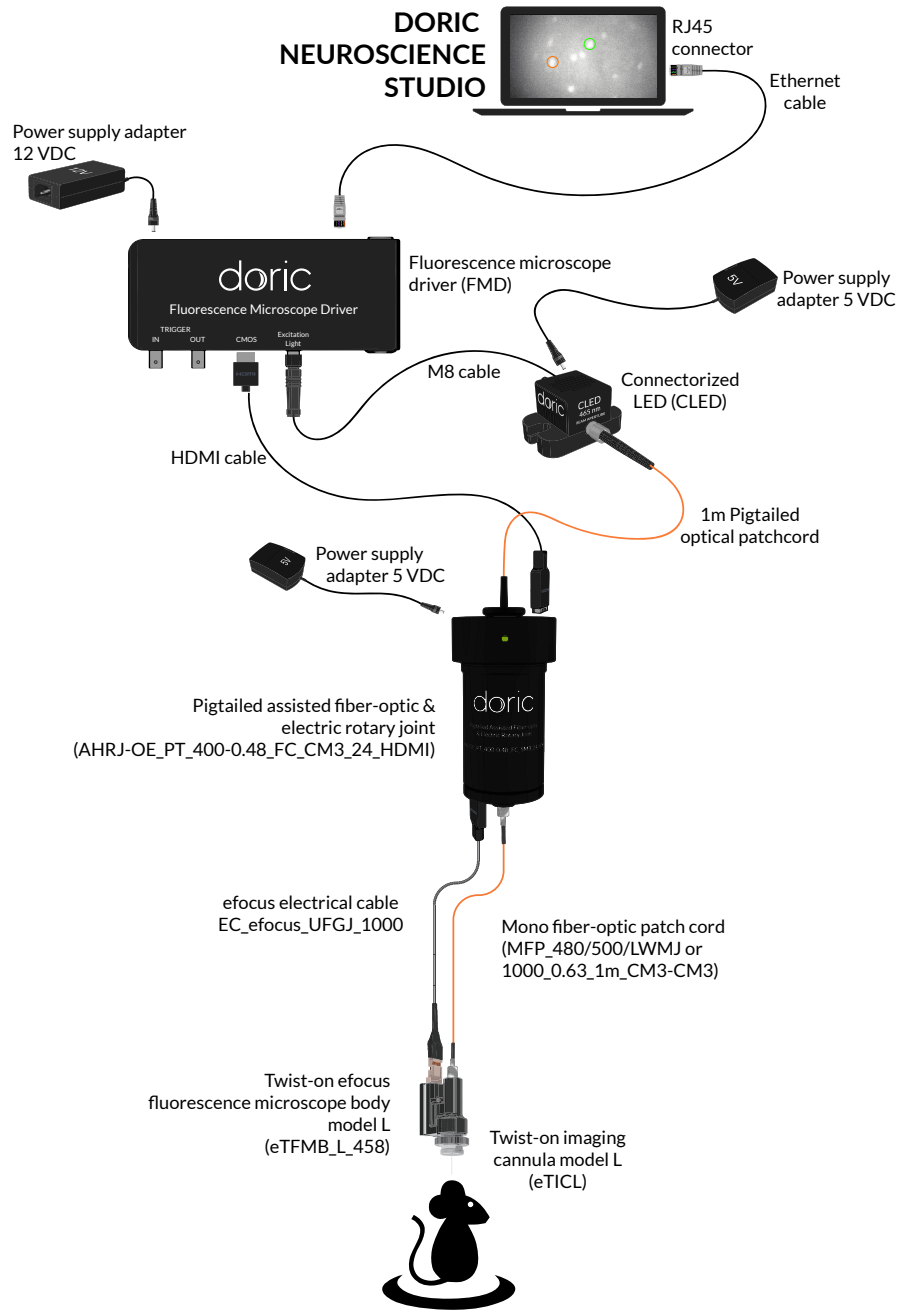

Figure 3.1: *Freely-moving System Configuration for Twist-on efocus Deep-brain Imaging.*

Handling & Cleaning

4.1 Important handling information

Warning: Handle the microscope and the cannula with care.

Miniature fluorescence microscopes are composed of sensitive electronic components and should always be handled with care. When they are not used, the microscope body with its cannula should be stored in a closed, dust-free environment. Some microscope components must be handled with extra care:

- **Electrical cable: Do not twist or pull on the cable.**
- **Relay lens:** The cannula lens is made of glass and is unprotected. **Abrasive materials can scratch the surface** and reduce the image quality.

The microscope bodies and the cannula lenses are made of glass, metal, plastic and the contact with organic tissues or liquids, like blood or saline solution is not recommended. While the cannula is designed to be in contact with such substances, the microscope body is not. If the body comes in contact with these substances, clean the optics (section 4.2) to avoid the appearance of stains.

4.2 Cleaning optics

The microscope objective lens should be cleaned before each use. The procedure explained here can also be used to clean the cannula relay lenses.

- Turn the driver OFF.
- **Wear gloves to manipulate the microscope.** Finger oil can stain the glass and is often difficult to remove properly.
- Use isopropyl alcohol on a cotton swab to gently clean the lens.
- **Do not blow on the optics.** Saliva particles will often stain the surface. Larger dust particles can be removed using a dust-free blower before cleaning with a cotton swab.

4.3 Imaging cannula reuse

The implanted cannulas are sold as disposable but can be re-used if removed carefully. To do so, simply remove the glued protrusion adjustment ring from the metal part. In this case, plan spare sets of protrusion adjustment rings. Acetone can be used to clean the cannula lens with a cotton swab (never dip the cannula in acetone), but care should be taken not to expose the binding site between the lens and the metal part of the cannula.

Support

5.1 Contact us

For any questions or comments, do not hesitate to contact us by:

Phone 1-418-877-5600

Email sales@doriclenses.com



© 2019 DORIC LENSES INC

357 rue Franquet - Quebec, (Quebec)

G1P 4N7, Canada

Phone: 1-418-877-5600 - Fax: 1-418-877-1008

www.doriclenses.com